

PSC-43X

SEATED CALF RAISE

OWNER'S MANUAL

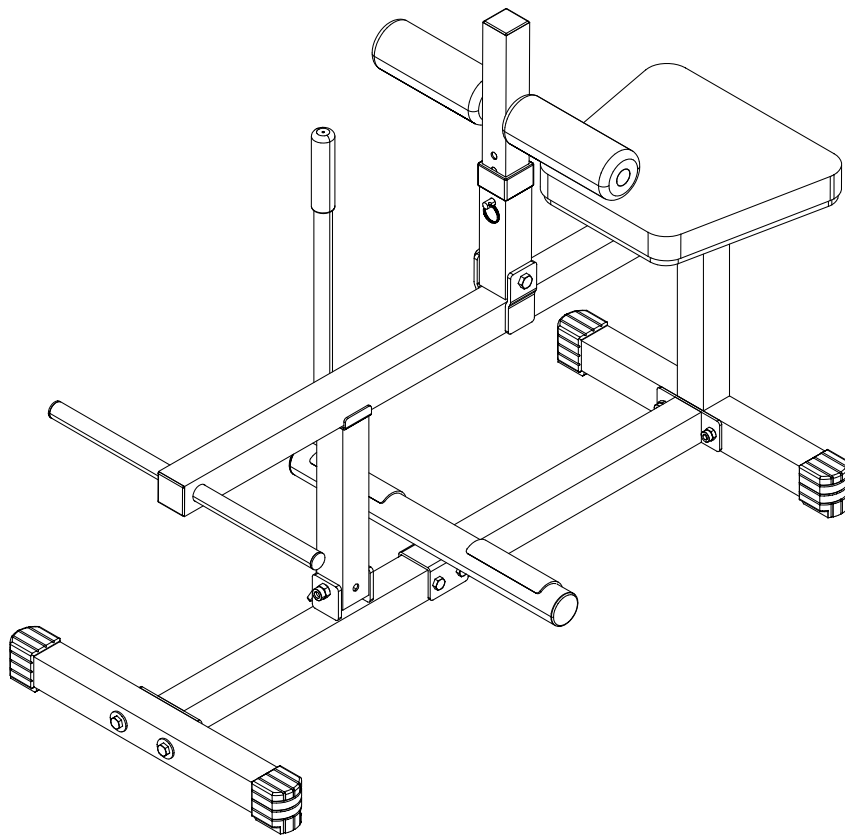

Архангельск (8182)63-90-72	Ижевск (3412)26-03-58	Магнитогорск (3519)55-03-13	Пермь (342)205-81-47	Сургут (3462)77-98-35
Астана (7172)727-132	Иркутск (395)279-98-46	Москва (495)268-04-70	Ростов-на-Дону (863)308-18-15	Тверь (4822)63-31-35
Астрахань (8512)99-46-04	Казань (843)206-01-48	Мурманск (8152)59-64-93	Рязань (4912)46-61-64	Томск (3822)98-41-53
Барнаул (3852)73-04-60	Калининград (4012)72-03-81	Набережные Челны (8552)20-53-41	Самара (846)206-03-16	Тула (4872)74-02-29
Белгород (4722)40-23-64	Калуга (4842)92-23-67	Нижний Новгород (831)429-08-12	Санкт-Петербург (812)309-46-40	Тюмень (3452)66-21-18
Брянск (4832)59-03-52	Кемерово (3842)65-04-62	Новокузнецк (3843)20-46-81	Саратов (845)249-38-78	Ульяновск (8422)24-23-59
Владивосток (423)249-28-31	Киров (8332)68-02-04	Новосибирск (383)227-86-73	Севастополь (8692)22-31-93	Уфа (347)229-48-12
Волгоград (844)278-03-48	Краснодар (861)203-40-90	Омск (3812)21-46-40	Симферополь (3652)67-13-56	Хабаровск (4212)92-98-04
Вологда (8172)26-41-59	Красноярск (391)204-63-61	Орел (4862)44-53-42	Смоленск (4812)29-41-54	Челябинск (351)202-03-61
Воронеж (473)204-51-73	Курск (4712)77-13-04	Оренбург (3532)37-68-04	Сочи (862)225-72-31	Череповец (8202)49-02-64
Екатеринбург (343)384-55-89	Липецк (4742)52-20-81	Пенза (8412)22-31-16	Ставрополь (8652)20-65-13	Ярославль (4852)69-52-93
Иваново (4932)77-34-06	Киргизия (996)312-96-26-47	Казахстан (772)734-952-31	Таджикистан (992)427-82-92-69	

Единый адрес для всех регионов: bda@nt-rt.ru || www.bodysolid.nt-rt.ru

PSC-43X

SAFETY INSTRUCTIONS

**WHEN USING EXERCISE EQUIPMENT,
YOU SHOULD ALWAYS TAKE BASIC
PRECAUTIONS INCLUDING THE
FOLLOWING:**

- Read all instructions before using the PSC-43X. These instructions are written to ensure your safety and to protect the unit.
- **Do not remove any safety labels from the machine.**
- Do not allow children on or near the equipment.
- Use the equipment only for its intended purpose as described in this guide. Do not use accessory attachments that are not recommended by the manufacturer. Such attachments might cause serious injuries.
- Wear proper exercise clothing and shoes for your workout, no loose clothing.
- Keep hands, limbs, loose clothing, and long hair well out of the way of all moving parts
- Use care when getting on or off the unit.
- Do not overexert yourself or work to exhaustion.
- If you feel any pain or abnormal symptoms, stop your workout immediately and consult your physician.
- Never operate unit when it has been dropped or damaged. Return the equipment to a service center for examination and repair.
- Never drop or insert objects into any opening in the equipment.
- Always check the unit and its cables before each use. Make sure that all fasteners and cables are secure and in good working condition.
- Do not use the equipment outdoors or near water.

PERSONAL SAFETY DURING ASSEMBLY

- Before beginning assembly, please take the time to read the instructions thoroughly.
- Read each step in the assembly instructions and follow the steps in sequence. Do not skip ahead. If you skip ahead, you may learn later that you have to disassemble components and that you may have damaged the equipment
- Assemble and operate the PSC-43X on a solid, level surface. Locate the unit a few feet from the walls or furniture to provide easy access.

The PSC-43X is designed for your enjoyment. By following these precautions and using common sense, you will have many safe and pleasurable hours of healthful exercise with your Powerline Seated Calf Raise Machine.

After assembly, you should check all functions to ensure correct operation. If you experience problems, first recheck the assembly instructions to locate any possible errors made during assembly. If you are unable to correct the problem, call the dealer from whom you purchased the machine or call 1-800-556-3113 for the dealer nearest you.

OBTAINING SERVICE

Please use this Owner's Manual to make sure that all parts have been included in your shipment. When ordering parts, you must use the part number and description from this Owner's Manual. Use only Powerline by Body Solid replacement parts when servicing this machine. Failure to do so will void your warranty and could result in personal injury.

For information about product operation or service, check out the official Powerline website at www.bodysolid.com or contact an authorized Powerline dealer or a Powerline factory-authorized service company or contact Body-Solid customer service at one of the following:

Toll Free: 1-800-556-3113
Phone: 1-708-427-3555
Fax: 1-708-427-3556
Email: service@bodysolid.com

Or write to: Body-Solid, Inc.
Service Department
1900 S. Des Plaines Ave.
Forest Park, IL 60130 USA

**RETAIN THIS OWNER'S MANUAL FOR
FUTURE REFERENCE. PART NUMBERS
ARE REQUIRED WHEN ORDERING PARTS.**

PSC-43X

PREPARATION

REQUIRED TOOLS

The basic tools that you must obtain before assembling the PSC-43X include but are not limit to:

- Standard Wrench Set
- Metric Wrench Set
- Adjustable Wrench
- Standard / Metric Allen Key Set

INSTALLATION REQUIREMENTS

Follow these installation requirements when assembling the PSC-43X:

Set up the PSC-43X on a solid, flat surface. A smooth, flat surface under the machine helps keep it level.

Provide ample space around the machine. Open space around the machine allows for easier access.

For aesthetic purposes, insert all bolts in the same direction unless specified (in text or illustrations) to do otherwise.

Leave room for adjustments. Tighten fasteners such as bolts, nuts, and screws so the unit is stable, but leave room for adjustments. Do not fully tighten fasteners until instructed in the assembly steps to do so.

Fill out and mail the warranty card.

ORDERING REPLACEMENT PARTS

If you need to order replacement parts please be prepared to provide the following information when contacting us so that we can assist you better.

1. Model Number
2. Place of Purchase
3. Serial Number (S/N)
4. Part # and Description

ASSEMBLY TIPS

Read all “Notes” on each page before beginning each step.

While you may be able to assemble the PSC-43X using the illustrations only, important safety notes and other tips may be included in the text.

Some pieces may have extra holes that you will not use. Use only those holes indicated in the instructions and illustrations.

NOTE: With so many assembled parts, proper alignment and adjustment is critical. While tightening the nuts and bolts, be sure to leave room for adjustments.

NOTE: The bottles that are marked “Poison” is your touch up paint. Keep away from children.

CAUTION: Obtain assistance! If you feel like you can't assemble the PSC-43X by yourself then do not attempt to do so as this could result in injury. Review the Installation Requirements before proceeding with the following steps.

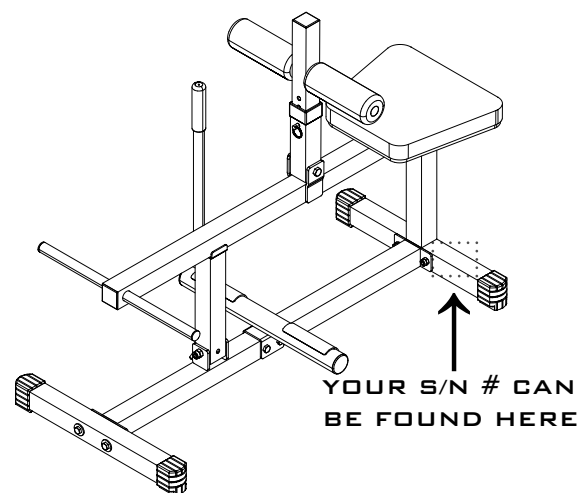

PSC-43X

HARDWARE LIST

<u>PART #</u>	<u>SIZE</u>	<u>DESCRIPTION</u>	<u>QUANTITY</u>
1	1/2"X3 1/2"	HEX HEAD BOLT	1 PCS.
2	M12X80mm	HEX HEAD BOLT	2 PCS.
3	M10X70mm	HEX HEAD BOLT	6 PCS.
4	5/16"X2 3/4"	HEX HEAD BOLT	2 PCS.
5	1/2"	NYLON LOCK NUT	1 PCS.
6	M12	NYLON LOCK NUT	2 PCS.
7	M10	NYLON LOCK NUT	6 PCS.
8	M10	WASHER	4 PCS.
9	5/16"	WASHER	2 PCS.
10	5/16"	SPRING WASHER	2 PCS.
11	2"X2"	FOOT CAP	4 PCS.
12	2"X2"	END CAP	4 PCS.
13	1 3/4"X1 3/4"	END CAP	2 PCS.
14	Ø48mm	ROUND END CAP	2 PCS.
15	Ø1"	ROUND END CAP	4 PCS.
16	50X45mm	NYLON BUSHING	1 PCS.
17	Ø1"X5"	RUBBER GRIP	1 PCS.
18		RUBBER BAR CUSHION	1 PCS.
19		RING PIN	1 PCS.
20	95X140mm	NO-SLIP TAPE	2 PCS.
21	Ø3 1/2"X8"	FOAM ROLLER	2 PCS.

PSC-43X

HARDWARE ILLUSTRATION

PART #1 **1/2" X 3 1/2" HEX HEAD BOLT** **QTY. 1**

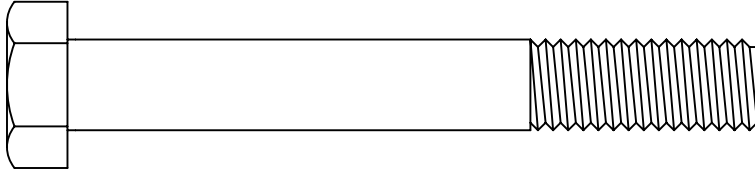

PART #2 **M12X80MM HEX HEAD BOLT** **QTY. 2**

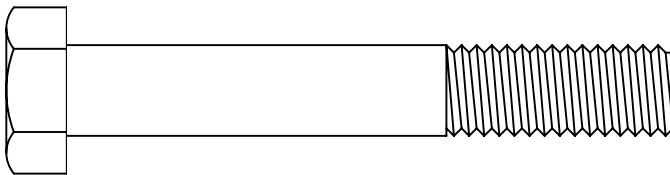

PART #3 **M10X70MM HEX HEAD BOLT** **QTY. 6**

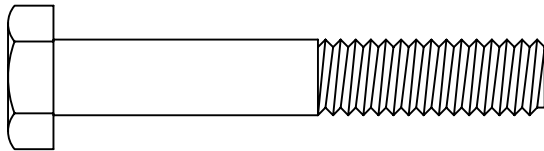

PART #4 **5/16" X 2 3/4" HEX HEAD BOLT** **QTY. 2**

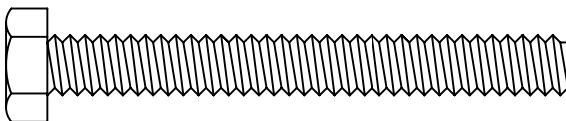

PART #5 **1/2" NYLON LOCK NUT** **QTY. 1**

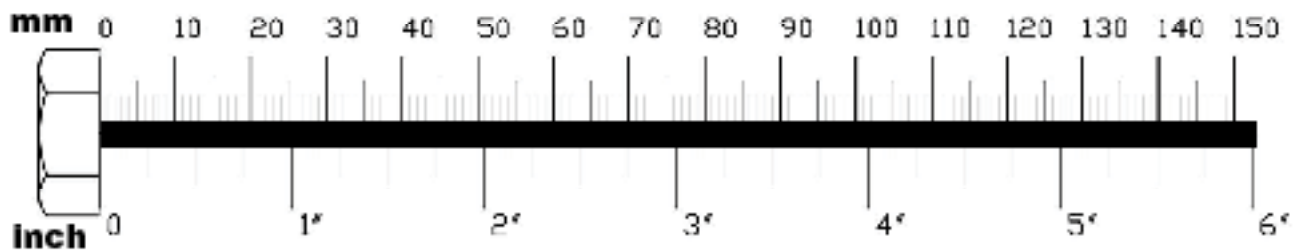

PSC-43X

HARDWARE LIST CONT.

PART #6

M12 NYLON LOCK NUT

QTY. 2



PART #7

M10 NYLON LOCK NUT

QTY. 6

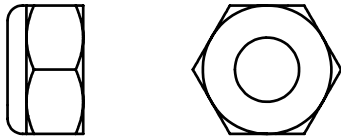

PART #8

M10 (I.D.) WASHER

QTY. 4

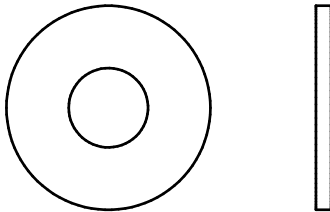

PART #9

5/16" (I.D.) WASHER

QTY. 2

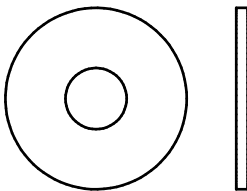

PART #10

5/16" SPRING WASHER

QTY. 2

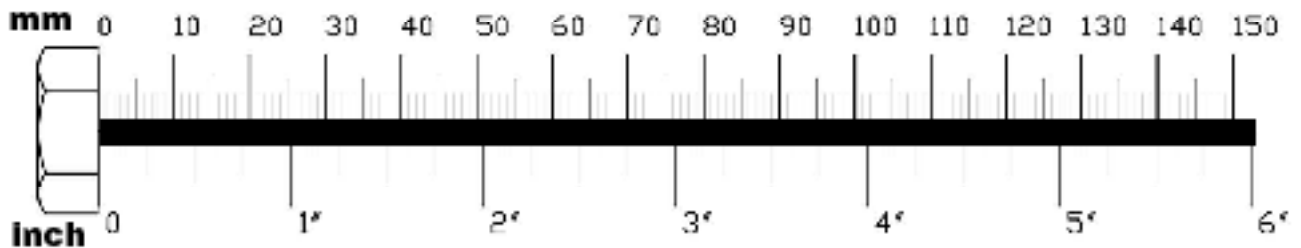
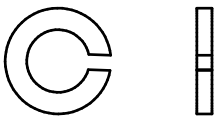

PSC-43X

HARDWARE ILLUSTRATION

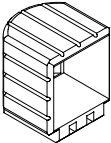
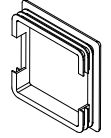
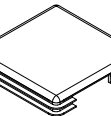
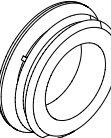
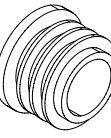
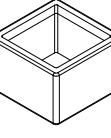
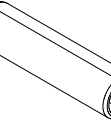
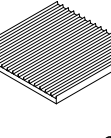
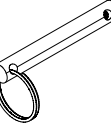
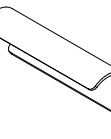
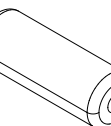
PART # 11		2"X2" FOOT CAP	QTY. 4
PART # 12		2"X2" END CAP	QTY. 4
PART # 13		1 3/4"X1 3/4" END CAP	QTY. 2
PART # 14		48MM DIA. ROUND END CAP	QTY. 2
PART # 15		1" DIA. ROUND END CAP	QTY. 4
PART # 16		50X45MM NYLON BUSHING	QTY. 1
PART # 17		1" DIA.X5" RUBBER GRIP	QTY. 1
PART # 18		RUBBER BAR CUSHION	QTY. 1
PART # 19		QUICK RELEASE RING PIN	QTY. 1
PART # 20		95X140MM NO-SLIP TAPE	QTY. 2
PART # 21		3 1/2" DIA.X8" FOAM ROLLER	QTY. 2

PSC-43X

PART LIST

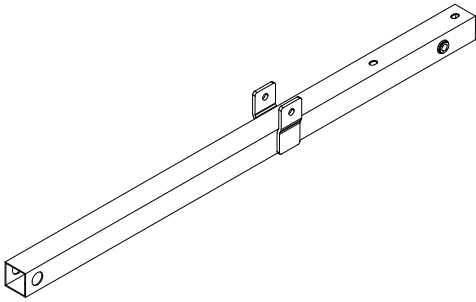

PART A
SUPPORT FRAME
[1 PCS]

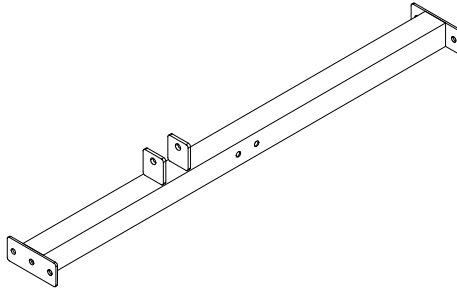

PART B
MAINFRAME
[1 PCS]

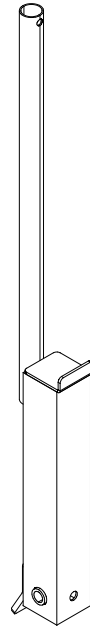

PART C
WEIGHT HOLDER
[1 PCS]

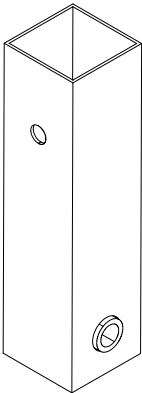

PART D
RING PIN FRAME
[1 PCS]

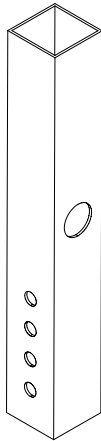

PART E
ROLLER ADJUSTER
[1 PCS]

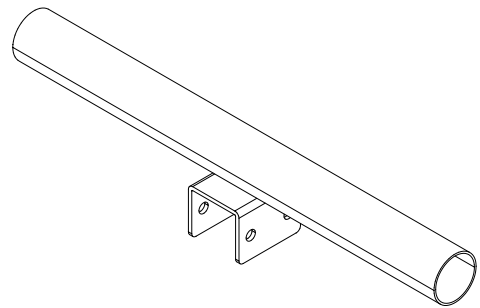

PART F
FOOT FRAME
[1 PCS]

PSC-43X
PART LIST CONT.

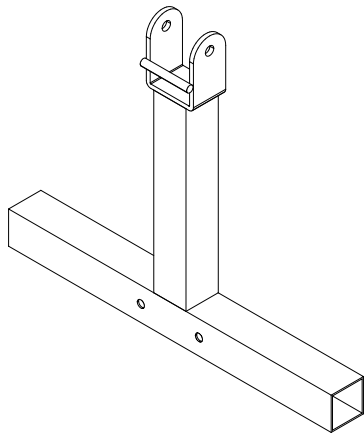

PART G
SEAT FRAME
[1 PCS]

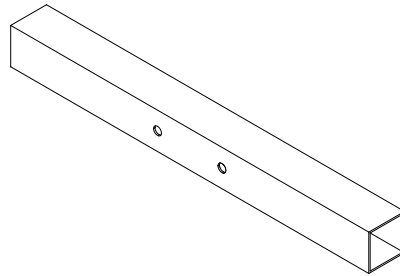

PART H
BASE FRAME
[1 PCS]

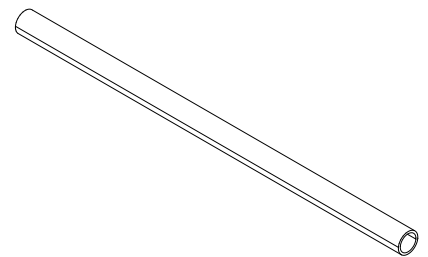

PART I
WEIGHT ROD
[1 PCS]

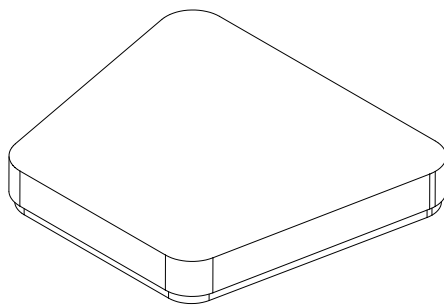

PART J
SEAT PAD
[1 PCS]

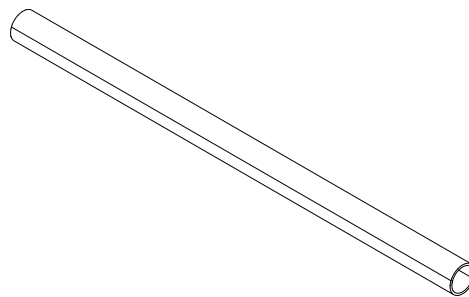

PART K
ROLLER ROD
[1 PCS]

NOTE: WEIGHT ROD (I) IS 500MM LONG AND ROLLER ROD (K) IS 445MM LONG

PSC-43X

STEP 1

BE CAREFUL TO ASSEMBLE ALL COMPONENTS IN THE SEQUENCE THAT THEY ARE PRESENTED.

NOTE:

FINGER TIGHTEN ALL HARDWARE IN THIS STEP. DO NOT WRENCH TIGHTEN UNTIL THE LAST STEP. SOME COMPONENTS MAY BE PRE-ASSEMBLED.

NYLON LOCK NUTS WILL NOT FULLY SCREW ONTO BOLTS, MUST WRENCH TIGHTEN.

1 A. ATTACH BASE FRAME (H) TO MAINFRAME (B) USING:

2 - (#3) M10X70MM HEX HEAD BOLT

2 - (#8) M10 WASHER

2 - (#7) M10 NYLON LOCK NUT

1 B. ATTACH SEAT FRAME (G) TO MAINFRAME (B) USING:

2 - (#3) M10X70MM HEX HEAD BOLT

2 - (#8) M10 WASHER

2 - (#7) M10 NYLON LOCK NUT

1 C. ATTACH FOOT FRAME (F) TO MAINFRAME (B) USING:

2 - (#3) M10X70MM HEX HEAD BOLT

2 - (#7) M10 NYLON LOCK NUT

1 D. INSERT FOOT CAPS ONTO ENDS OF BASE FRAME (H) AND SEAT FRAME (G) USING:

4 - (#11) 2"X2" FOOT CAP

1 E. INSERT END CAPS INTO ENDS OF FOOT FRAME (F) USING:

2 - (#14) 48MM DIA. ROUND END CAP

1 F. INSERT NO-SLIP TAPE ON TOP SURFACE OF FOOT FRAME (F) USING:

2 - (#20) 95X140MM NO-SLIP TAPE

PSC-43X

STEP 1

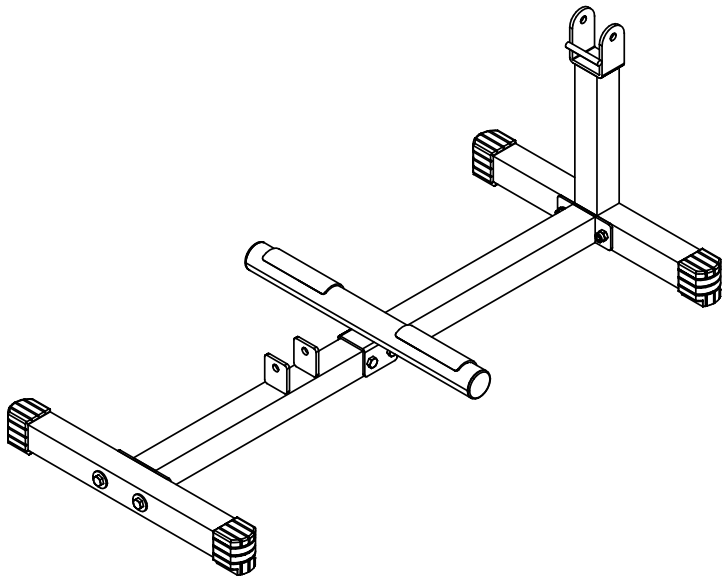

ABOVE SHOWS STEP 1
ASSEMBLED AND COMPLETED

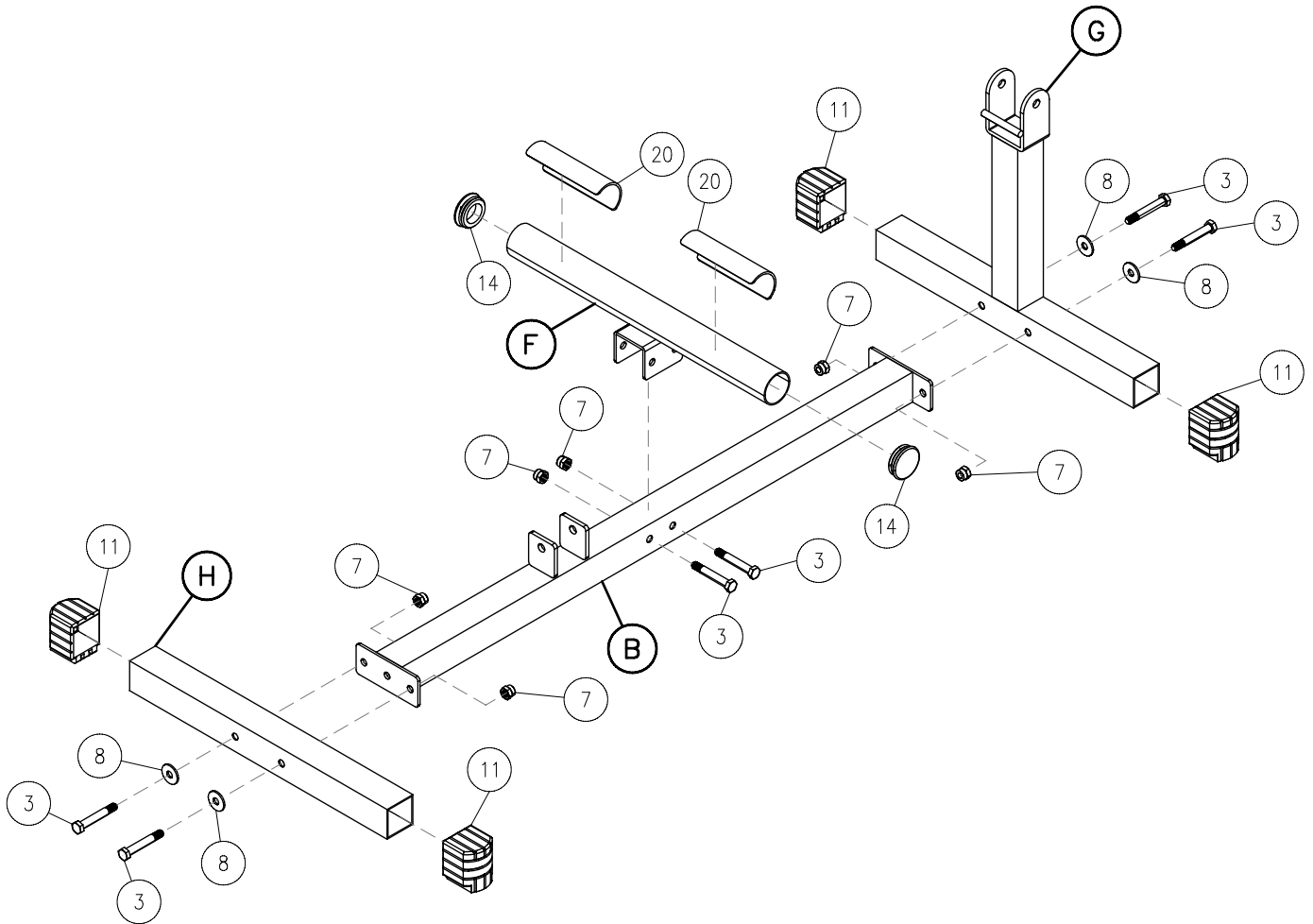

PSC-43X

STEP 2

BE CAREFUL TO ASSEMBLE ALL COMPONENTS IN THE SEQUENCE THAT THEY ARE PRESENTED.

NOTE:

FINGER TIGHTEN ALL HARDWARE IN THIS STEP. DO NOT WRENCH TIGHTEN UNTIL THE LAST STEP. SOME COMPONENTS MAY BE PRE-ASSEMBLED.

NYLON LOCK NUTS WILL NOT FULLY SCREW ONTO BOLTS, MUST WRENCH TIGHTEN.

2A. INSERT END CAP, ATTACH RUBBER BAR CUSHION, AND SLIDE ON RUBBER GRIP TO WEIGHT HOLDER (C) USING:

- 1 - (#12) 2"X2" END CAP
- 1 - (#18) RUBBER BAR CUSHION
- 1 - (#17) 1" DIA.X5" RUBBER GRIP

2B. ATTACH WEIGHT HOLDER (C) TO MAINFRAME (B) USING:

- 1 - (#2) M12X80MM HEX HEAD BOLT
- 1 - (#6) M12 NYLON LOCK NUT

2C. ATTACH SUPPORT FRAME (A) TO SEAT FRAME (G) USING:

- 1 - (#1) 1/2"X 3 1/2" HEX HEAD BOLT
- 1 - (#5) 1/2" NYLON LOCK NUT

2D. ATTACH SEAT PAD (J) TO SUPPORT FRAME (A) USING:

- 2 - (#4) 5/16"X 2 3/4" HEX HEAD BOLT
- 2 - (#10) 5/16" SPRING WASHER
- 2 - (#9) 5/16" WASHER

2E. INSERT END CAPS INTO BOTH ENDS OF SUPPORT FRAME (A) USING:

- 2 - (#12) 2"X2" END CAP

2F. INSERT WEIGHT ROD (I) INTO OPENING AT FRONT OF SUPPORT FRAME (A), SECURE BY TIGHTENING M10X25MM BOLT AND NUT AND INSERT END CAPS INTO ENDS OF WEIGHT ROD USING:

- 2 - (#15) 1" DIA. ROUND END CAP.

PSC-43X

STEP 2

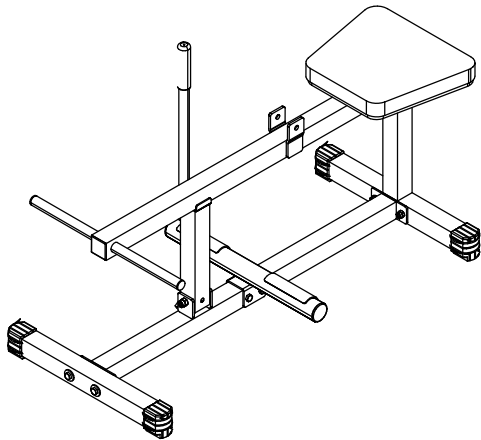

ABOVE SHOWS STEP 2
ASSEMBLED AND COMPLETED

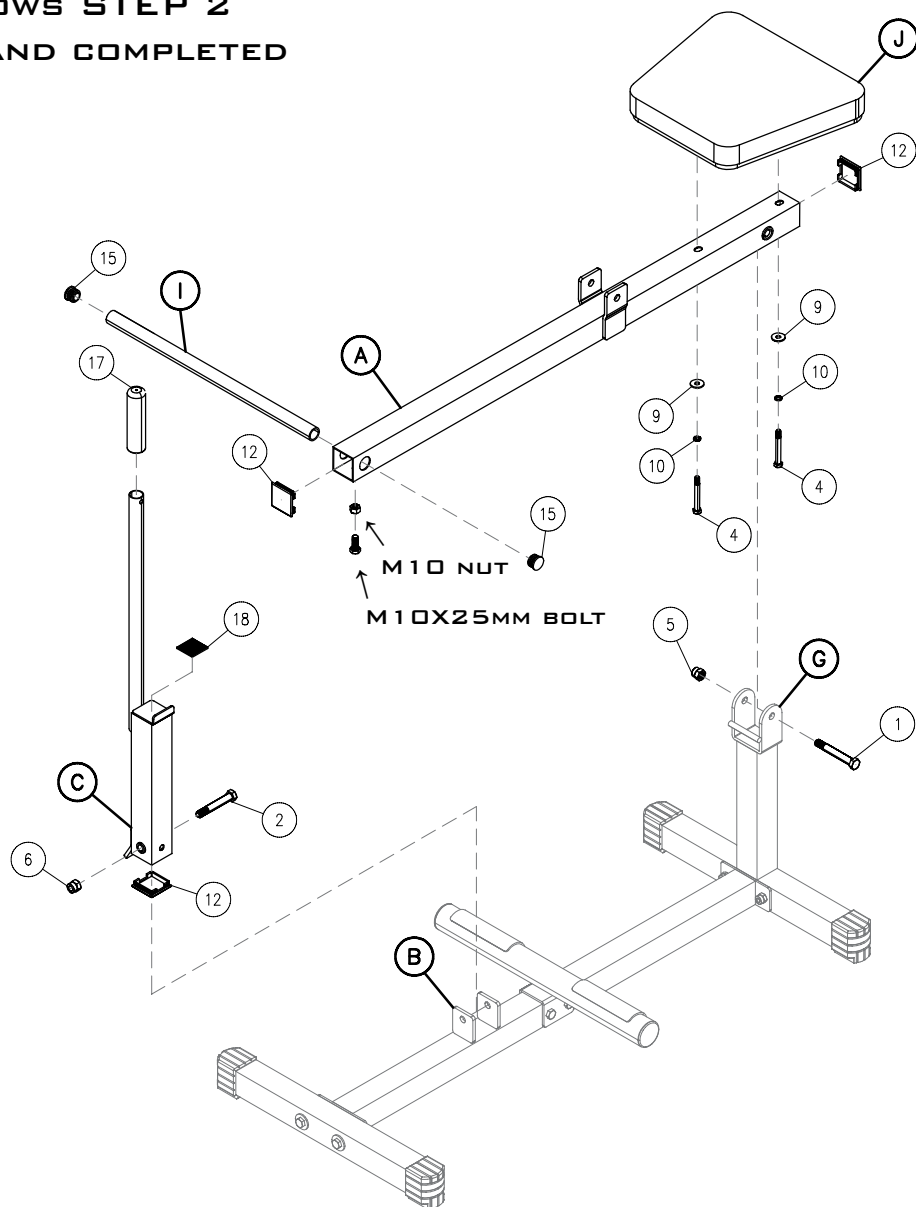

PSC-43X

STEP 3

BE CAREFUL TO ASSEMBLE ALL COMPONENTS IN THE SEQUENCE THAT THEY ARE PRESENTED.

NOTE:

FINGER TIGHTEN ALL HARDWARE IN THIS STEP. DO NOT WRENCH TIGHTEN UNTIL THE LAST STEP. SOME COMPONENTS MAY BE PRE-ASSEMBLED.

NYLON LOCK NUTS WILL NOT FULLY SCREW ONTO BOLTS, MUST WRENCH TIGHTEN.

3A. INSERT END CAP INTO BOTTOM OPENING AND SLIDE NYLON BUSHING ONTO TOP OPENING OF RING PIN FRAME (D) USING:

- 1 - (#12) 2"X2" END CAP
- 1 - (#16) 50X45MM NYLON BUSHING

3B. ATTACH RING PIN FRAME (D) TO SUPPORT FRAME (A) USING:

- 1 - (#2) M12X80MM HEX HEAD BOLT
- 1 - (#6) M12 NYLON LOCK NUT

3C. INSERT END CAPS INTO BOTH ENDS OF ROLLER ADJUSTER (E) USING:

- 2 - (#13) 1 3/4"X1 3/4" END CAP

3D. SLIDE ROLLER ADJUSTER (E) INTO RING PIN FRAME (D) AND SECURE USING:

- 1 - (#19) QUICK RELEASE RING PIN

3E. SLIDE ROLLER ROD (K) INTO OPENING OF RING PIN FRAME (D) AND INSERT A FOAM ROLLER AND ROUND END CAP ONTO EACH SIDE OF ROLLER ROD (K) USING:

- 2 - (#21) 3 1/2" DIA.X8" FOAM ROLLER
- 2 - (#15) 1" DIA. ROUND END CAP

PSC-43X

STEP 3

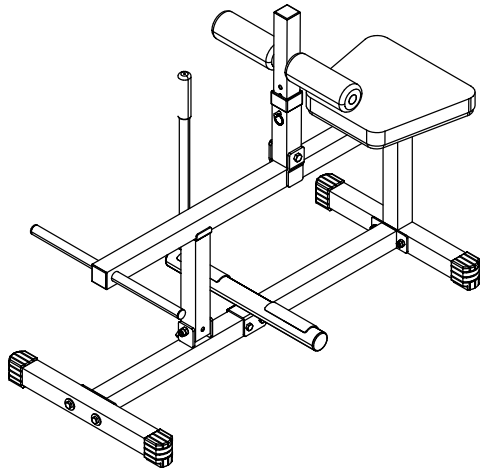

ABOVE SHOWS STEP 3
ASSEMBLED AND COMPLETED

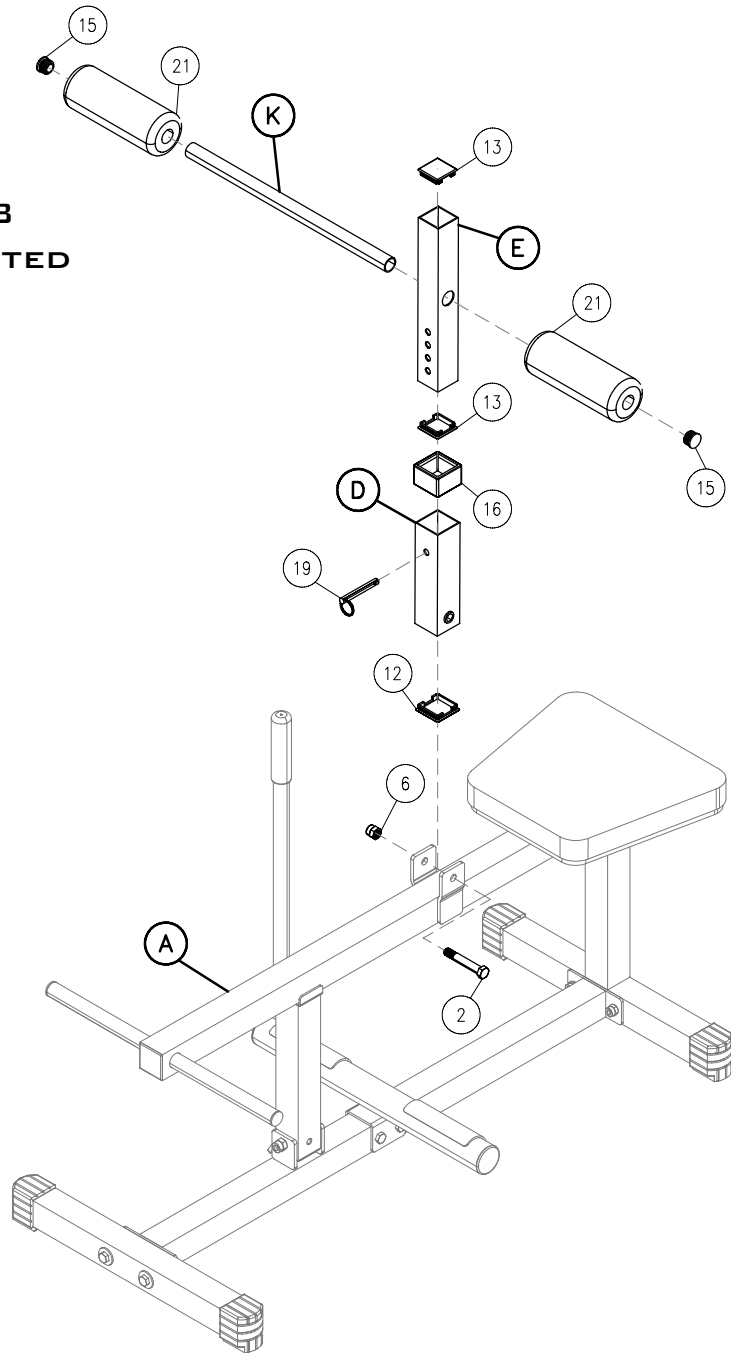

PSC-43X

EXPLODED VIEW

